



Bulletin MSG11-5715-687/UK

Operation Manual Series DFplus

Design > 30

Proportional Directional Control Valve



Parker Hannifin
Manufacturing Germany GmbH & Co. KG
Industrial Systems Division Europe
Gutenbergstr. 38
41564 Kaarst, Germany
E-mail: isde.kaarst.support@support.parker.com
Copyright © 2021, Parker Hannifin Corp.



WARNING – USER RESPONSIBILITY

FAILURE OR IMPROPER SELECTION OR IMPROPER USE OF THE PRODUCTS DESCRIBED HEREIN OR RELATED ITEMS CAN CAUSE DEATH, PERSONAL INJURY AND PROPERTY DAMAGE.

This document and other information from Parker-Hannifin Corporation, its subsidiaries and authorized distributors provide product or system options for further investigation by users having technical expertise.

The user, through its own analysis and testing, is solely responsible for making the final selection of the system and components and assuring that all performance, endurance, maintenance, safety and warning requirements of the application are met. The user must analyze all aspects of the application, follow applicable industry standards, and follow the information concerning the product in the current product catalog and in any other materials provided from Parker or its subsidiaries or authorized distributors.

To the extent that Parker or its subsidiaries or authorized distributors provide component or system options based upon data or specifications provided by the user, the user is responsible for determining that such data and specifications are suitable and sufficient for all applications and reasonably foreseeable uses of the components or systems.

| Contents | Page |
|--|-------------|
| 1. Introduction | 4 |
| Ordering Code D*FE | 4 |
| Ordering Code D*FP | 5 |
| Ordering Code D30FP | 6 |
| Name Plate | 7 |
| Characteristics of Valve Driver | 7 |
| Block Diagram of Onboard Electronics | 7 |
| Technical Data | 8 |
| 2. Safety Instructions | 9 |
| Symbols | 9 |
| Service | 9 |
| 3. Important Details | 9 |
| Intended Usage | 9 |
| Common Instructions | 9 |
| Liability | 9 |
| Storage | 9 |
| 4. Mounting / Installation | 10 |
| Scope of Supply | 10 |
| Mounting | 10 |
| Limits of Use | 10 |
| Pressure Fluids | 10 |
| Electrical Connection | 11 |
| 5. Operating Instructions | 15 |
| Spool Position at Power Down/Center Position | 15 |
| ProPxD parameterizing software | 15 |
| Filter | 20 |
| Flushing | 20 |
| 6. Trouble Shooting | 21 |
| 7. Accessories / Spare Parts | 21 |
| Accessories | 21 |
| Spare Parts | 21 |

1. Introduction

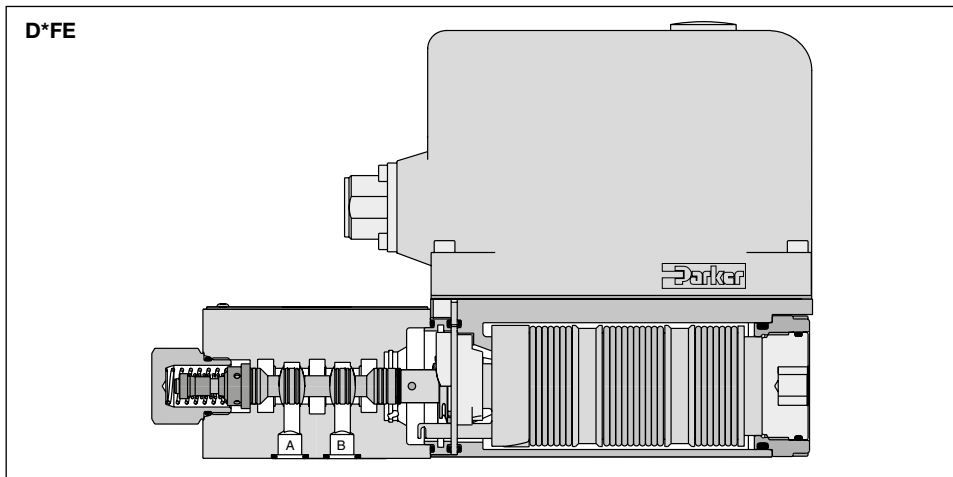

Ordering Code

| | | | | | | | | | | | |
|-----------------------------|---------------------|---|---|--------------------------------------|-------------------------------------|--------------------------------------|-------------|-----------------------|----------------------------|--------------------------|---|
| D | | F | E | | C | 9 | | | | 3 | |
| Direct control valve | Nominal size | | | Spool-type (see catalogue) | Spool position on power down | Y-port (plugged)¹⁾ | Seal | Command-signal | Elec-tronics option | Spool/body design | Design series (not required for ordering) |

| Code | Size |
|------|------------------|
| 1 | NG06 / CETOP 03 |
| 3 | NG010 / CETOP 05 |

| Code | Spool position on power down |
|------|------------------------------|
| C | |

| Code | Seal |
|------|---------------|
| N | NBR |
| V | FPM |
| H | for HFC fluid |

| Code | Connection |
|------|-----------------|
| 0 | 6 + PE |
| 5 | 11 + PE |
| 7 | 6 + PE + Enable |

| Code | Signal | Function |
|------|-----------|-------------------|
| B | +/- 10 V | 0...+10 V -> P-A |
| E | +/- 20 mA | 0...+20 mA -> P-A |
| K | +/- 10 V | 0...+10 V -> P-B |
| S | 4...20 mA | 12...20 mA -> P-A |

¹⁾ Needs to be removed at tank pressure >35 bar.

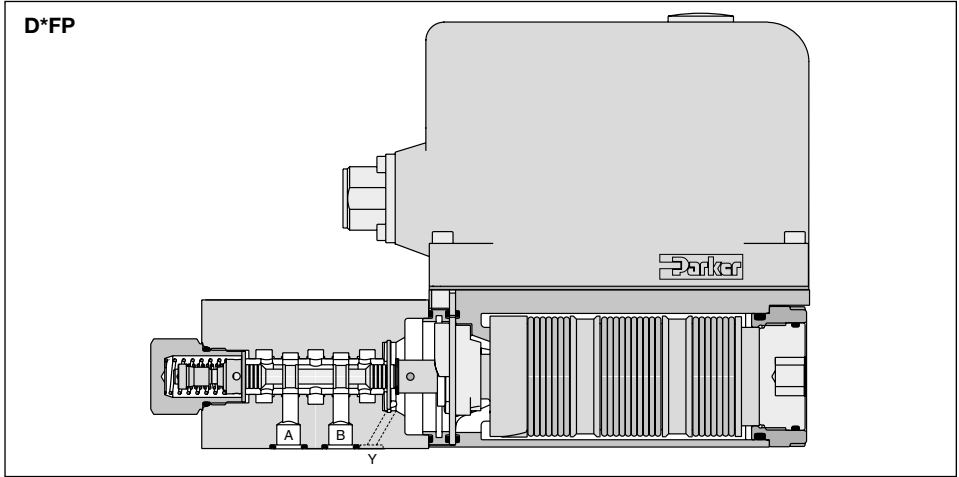

Ordering Code

| | | | | | | | | | | | |
|------------------------------|---------------------|---|---|---|---|---------------------------------------|-------------|-----------------------|---------------------------|----------------------------|--|
| D | | F | P | | | 9 | | | | 0 | |
| Direct. control valve | Nominal size | | | Spool-type <small>(see catalogue)</small> | Spool position on power down ¹⁾ | Y-port (plugged) ²⁾ | Seal | Command-signal | Electronics option | Spool/sleeve design | Design series <small>(not required for ordering)</small> |

| Code | Nominal size |
|------|-----------------|
| 1 | NG06 / CETOP 03 |
| 3 | NG10 / CETOP 05 |

| Code | Connection |
|------|-----------------|
| 0 | 6 + PE |
| 5 | 11 + PE |
| 7 | 6 + PE + Enable |

| Code | Spool position on power down | Code | Spool position on power down |
|-----------------|------------------------------|--------------------|------------------------------|
| A ³⁾ | | H ^{5) 6)} | |
| B ³⁾ | | J ^{5) 6)} | |
| C ⁴⁾ | | | |

| Code | Signal | Function |
|------|-----------|-------------------|
| B | +/- 10 V | 0...+10 V -> P-A |
| E | +/- 20 mA | 0...+20 mA -> P-A |
| K | +/- 10 V | 0...+10 V -> P-B |
| S | 4...20 mA | 12...20 mA -> P-A |

| Code | Seal |
|------|---------------|
| N | NBR |
| V | FPM |
| H | for HFC fluid |

- 1) On power down the spool moves in a defined position.
This cannot be guaranteed in case of single flow path on the control edge A – T resp. B – T with pressure drops above 120 bar or contamination in the hydraulic fluid.
- 2) Needs to be removed at tank pressure >35 bar.
- 3) Approx. 10 % opening, only zero lapped spools and underlap spools.
- 4) Only for overlapped spools.
- 5) D1FP: Flow for code M: 35 l/min at Δp 35 bar.
- 6) Only D1FP

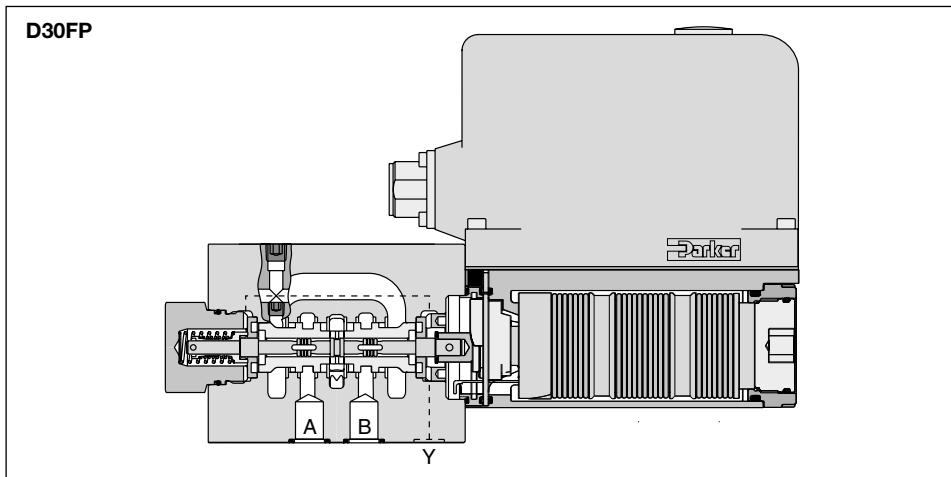

Ordering Code

| | | | | | | | | | | | |
|-----------------------------|-------------------------------------|----------|----------|-----------------------------------|-------------------------------------|-------------------------|-------------|-----------------------|---------------------------|--------------------------|--|
| D | 30 | F | P | | | | | | 3 | | |
| Direct control valve | Nominal size NG10 / CETOP 05 | | | Spool-type (see catalogue) | Spool position on power down | Pilot connection | Seal | Command-signal | Electronics option | Spool/body design | Design series (not required for ordering) |

| Code | Spool position on power down |
|-----------------|------------------------------|
| A ¹⁾ | |
| B ¹⁾ | |
| C ²⁾ | |

| Code | Inlet | Drain |
|-----------------|----------|----------|
| 1 ³⁾ | internal | external |
| 4 | internal | internal |

| Code | Connection |
|------|-----------------|
| 0 | 6 + PE |
| 5 | 11 + PE |
| 7 | 6 + PE + Enable |

| Code | Signal | Function |
|------|-----------|-------------------|
| B | +/- 10 V | 0...+10 V -> P-A |
| E | +/- 20 mA | 0...+20 mA -> P-A |
| K | +/- 10 V | 0...+10 V -> P-B |
| S | 4...20 mA | 12...20 mA -> P-A |

| Code | Seal |
|------|---------------|
| N | NBR |
| V | FPM |
| H | for HFC fluid |

¹⁾ Approx. 10 % opening, only zerolapped spools.

²⁾ Only for overlapped spools.

³⁾ For tank pressure >35 bar.

Operation Manual

Prop. Directional Control Valve Series DFplus

Name Plate

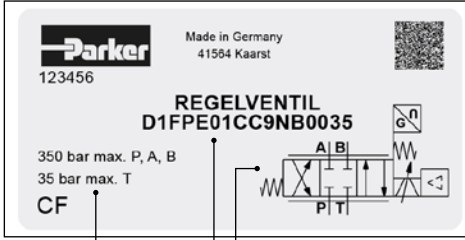

hydr. spool symbol
order code
nominal pressure

Characteristics of Valve Driver

The integral electronic driver combines all functions for optimal operation of the valve. Thanks to its excellent dynamic the valve is deployable within closed loop control applications. The most important features are:

- high dynamic actuator with specially designed electronic driver
- closed loop controlled spool position
- constant current actuator control with overcurrent shutoff
- excellent properties for response sensitivity and temperature drift
- differential input stage with various command signal options
- diagnostic output for spool stroke / overcurrent state
- meets relevant European EMC-standards



¹⁾ Do not connect with supply voltage zero.

Block Diagram of Onboard Electronics

Code 0 (6+PE)

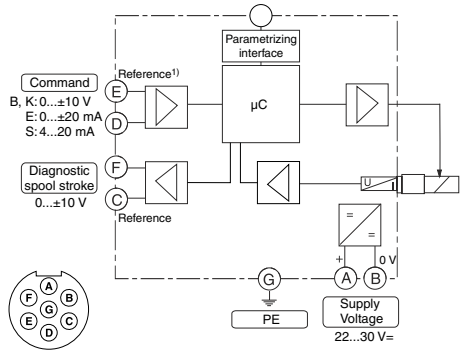

Code 5 (11+PE)

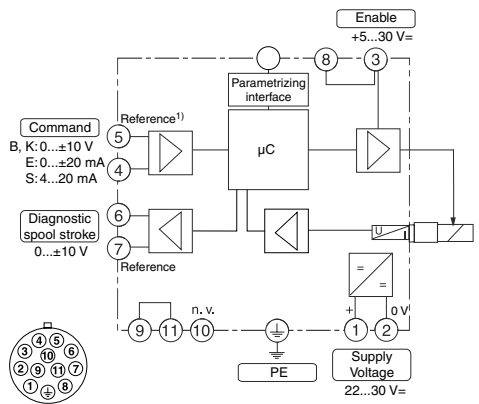

Code 7 (6+PE with enable)

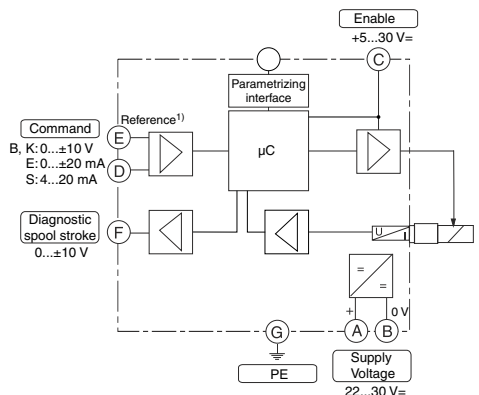

Technical Data

| General | | |
|----------------------------------|-----------------|--|
| Model | | Proportional directional control valve, direct operated (D*FE, D*FP), pilot operated (D30FP) |
| Drive | | VCD®-actuator |
| Mounting interface | | NG06 (CETOP 03) / NG10 (CETOP 05) |
| Installation position | | D*FE, D*FP: unrestricted; D30FP: horizontal mounting preferred (other mounting positions after consultation) |
| Sensitivity | [%] | < 0.03 |
| Hysteresis | [%] | < 0.05 (D*FE: <0.1) |
| Temp. drift of center position | [%/K] | < 0.025 |
| Ambient temperature | [°C] | -20...+50 |
| Vibration resistance | [G] | 10 Sinus 5...2000 Hz acc. IEC 68-2-6 10 (RMS) Random noise 20...2000 Hz acc. IEC 68-2-36 15 Shock acc. IEC 68-2-27 |
| Weight | [kg] | NG06: 3.6 / NG10: 6.5 |
| Hydraulic | | |
| Fluid | | Hydraulic oil according to DIN 51524 ... 535, other on request |
| Fluid temperature | [°C] | -20...+60 (NBR: -25...+60) |
| Viscosity permitted | [cSt] / [mm²/s] | 20...400 |
| recommended | [cSt] / [mm²/s] | 30...80 |
| Filtration | | ISO 4406; 18/16/13 |
| Operating pressure max. | [bar] | 350 for ports P, A, B / max. 35 for port T at internal drain, 250 (D1FE, D1FP: 350) at external drain / port Y max. 35 ¹⁾ |
| Electrical | | |
| Duty ratio | [%] | 100 |
| Protection class | | IP65 in accordance with EN 60529 (with correctly mounted plug-in connector) |
| Supply voltage / ripple | [V] | 22...30, electric shut-off < 19, ripple < 5 % eff., surge free |
| Current consumption max. | [A] | 3.5 |
| Pre-fusing | [A] | 4.0 A medium lag |
| Input signal Code B, (K) voltage | [V] | +10...0...-10, ripple < 0.01 % eff., surge free, 0...+10 V P→A (P→B) |
| Impedance | [kOhm] | 100 |
| Code E voltage | [mA] | +20...0...-20, ripple < 0.01 % eff., surge free, 0...+20 mA P→A |
| Impedance | [Ohm] | < 250 |
| Code S current | [mA] | 4...12...20, ripple < 0.01 % eff., surge free, 12...20 mA P→A |
| Impedance | [Ohm] | < 250 |
| | | < 3.6 mA = enable off, > 3.8 mA = enable on acc. NAMUR NE43 |
| Input capacitance typ. | [nF] | 1 |
| Differential input voltage max. | [V] | 30 for terminal D and E against PE (terminal G) |
| Code 0 | | 11 for terminal D and E against 0V (terminal B) |
| Code 5 | [V] | 30 for terminal 4 and 5 against PE (terminal \perp) 11 for terminal 4 and 5 against 0V (terminal 2) |
| Code 7 | [V] | 30 for terminal D and E against PE (terminal G) |
| Enable signal Code 5/7 | [V] | 5...30, Ri = > 8 kOhm |
| Diagnostic signal | [V] | +10...0...-10 / +12.5 error detection, rated max. 5 mA |
| EMC | | EN 61000-6-2, EN 61000-6-4 |
| Electrical connection | | |
| Code 0/7 | | 6 + PE acc. EN 175201-804 |
| Code 5 | | 11 + PE acc. EN 175201-804 |
| Wiring min. Code 0/7 | [mm²] | 7 x 1.0 (AWG16) overall braid shield |
| Code 5 | [mm²] | 8 x 1.0 (AWG16) overall braid shield |
| Wiring length max. | [m] | 50 |

¹⁾ For applications with $p_T > 35$ bar (max 350 bar) the Y-port has to be connected and the plug in the Y-port has to be removed.

2. Safety Instructions

Please read the operation manual before installation, start-up, service, repair or stocking! Disregard may result in damaging the valve or incorporated system parts.

Symbols

This manual uses symbols which have to be followed accordingly:



Instructions with regard to the warranty



Instructions with regard to possible damaging of the valve or linked system components



Helpful additional instructions

Service

Workings in the area of installation, commissioning, maintenance and repair of the valve may only be allowed by qualified personnel. These are persons which have, because of education, experience and instruction, sufficient knowledge on relevant directives and approved technical rules.

3. Important Details

Intended Usage

This operation manual is valid for proportional directional control valves DFplus series. Any different or unintended usage is to be considered as not intended. The manufacturer is not liable for warranty claims resulting from this.

Common Instructions

Parker reserves the right for technical modifications of the described product. Illustrations and drawings within this manual are simplified representations. Due to improvement or modification of the product the illustrations might not match precisely with the described valve. The technical specifications and dimensions are not binding. No claims can be derived of it. Copyrights are reserved.

Liability

Parker does not assume liability for damage due to the following failures:

- incorrect mounting / installation
- improper handling
- lack of maintenance
- unintended usage



Do not disassemble the valve! In case of suspicion for a defect please contact Parker.

Storage

In case of temporary storage the valve must be protected against contamination, atmospheric exposure and mechanical damages. Each valve has been factory tested with hydraulic oil, resulting in protection of the internal parts against corrosion. Yet this protection is only ensured under the following conditions:

| Storage period | Storage requirements |
|----------------|--|
| 12 months | constant humidity < 60 % as well as constant temperature < 25 °C |
| 6 months | varying humidity as well as varying temperature < 35 °C |



Outdoor storage or within sea and tropical climate will lead to corrosion and might disable the valve!

Operation Manual

4. Mounting / Installation

Scope of Supply

Please check immediately after receiving the valve, if the content is matching with the specified scope of supply. The delivery includes:

- valve
- operation manual

The central connector has to be ordered separately and is not included in the delivery.

 Please check the delivery immediately after receiving the shipment for apparent damages due to shipping. Report shipment losses at once to the carrier and the supplier!

Mounting

- Compare valve type (located on the name plate) with bill of materials respectively circuit diagram.
- The valve may be mounted fix or movable in any direction.
- Check mounting surface for the valve. Unevenness of 0.01 mm/100 mm, surface finish of 6.3 µm are tolerable values.

 Keep valve mounting surface and work environment clean!

- Remove protection plate from the valve mounting surface
- Check the proper position of the valve ports and the O-rings.
- Mounting bolts:
 D1FE/D1FP: 4 pcs. M5x30
 D3FP/D30FP: 4 pcs. M6x40
 use property class ISO 4762-12.9
- Bolt kits:
 D1FE/D1FP: BK375
 D3FE/D3FP/D30FP: BK385
- Tighten the bolts crisscross with the following torque values:
 D1FE/D1FP: 7.6 Nm
 D3FE/D3FP/D30FP: 13.2 Nm

 Insufficient condition of the valve mounting surface might create malfunction!
 Incorrect mounting resp. bolt torque may result in abrupt leakage of pressure fluid on the valve ports.

Limits of Use

The valve may be operated within the determined limits only. Please refer to the “technical data“ section as well as to the “characteristic curves“ in the Parker catalogue HY11-3500/UK “Hydraulic Valves Industrial Standard“.

 Follow the environmental conditions! Unallowable temperatures, shock load, aggressive chemicals exposure, radiation exposure, illegal electromagnetic emissions may result in operating trouble and may lead to failure!
 Follow the operating limits listed in the “specifications“ table!

Pressure Fluids

The following rules applies for the operation with various pressure fluids:

 This above information serves for orientation and does not substitute user tests among the particular operating conditions. In particular, no liability for media compatibility may be derived out of it.

Mineral oil: usable without restriction.

HFC: choose the right seal option.

For operation with the following pressure fluids please consult Parker:

| | |
|-----|-----------------------------------|
| HFA | oil-in-water emulsion |
| HFB | water-in-oil emulsion |
| HFD | unhydrous fluids (Phosphor-Ester) |

 For detailed information concerning pressure fluids note VDMA-document 24317 as well as DIN 51524 & 51502.

Special gaskets may be available depending on the utilized fluid.

In case of doubt please consult Parker.

Operation Manual

Electrical Connection

The valve is connected electrically by one common cable and a central connector.

The connection codes 0 and 7 require a 6 + PE female connector EN 175201-804.

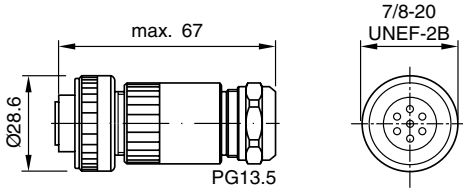

The connection Code 5 requires a 11 + PE female connector EN 175201-804.

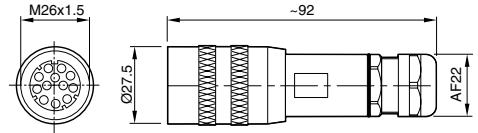

☞ The female connector can be ordered separately under article nr. 5004072.

⚠ In case third party connectors are used, accordance to the relevant EMC directives must be ensured.

The connecting cable has to comply to the following specification:

| | |
|-----------------|---|
| Cable type | control cable, flexible, 7 conductors, overall braid shield |
| Cross section | min. AWG16 |
| Outer dimension | 8...12 mm |
| Cable length | max. 50 m |

☞ For cable lengths > 50 m consult Parker.

The connection cable is coupled to the female connector by solder joints.

Stripping lengths for the connecting cable:

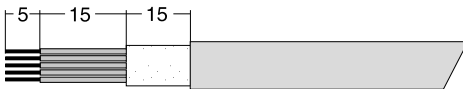

☞ The female connector has to be ordered separately under article nr. 5004711.

⚠ In case third party connectors are used, accordance to the relevant EMC directives must be ensured.

The connecting cable has to comply to the following specification:

| | |
|-----------------|---|
| Cable type | control cable, flexible, 8 conductors, overall braid shield |
| Cross section | min. AWG16 |
| Outer dimension | 12...15 mm |
| Cable length | max. 50 m |

☞ For cable lengths > 50 m consult factory.

The connection cable is coupled to the female connector by crimp contacts.

Stripping lengths for the connecting cable:



⚠ Do not disconnect cable socket under voltage!

The shielding has to be assembled according the outline below:

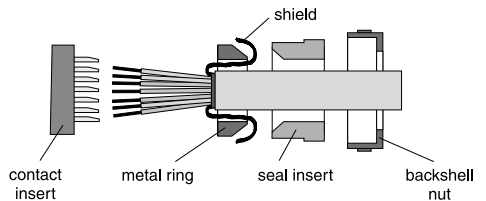

The backshell nut of the cable gland has to be tightened with a suitable tool. The target value for the tightening torque is 4 Nm. Tighten the cap nut with a torque of 5 Nm after attaching the female connector on the socket.

 Incomplete tightening of backshell nut respectively cap nut may result in undesired release of the connection as well as degradation of the water tightness.

When using female connectors of other manufacturers, the relevant regulations must be observed.

 The cable may only be connected to the female connector by authorized and qualified personnel. A short between individual conductors resp. to the connector housing, bad soldering as well as improper shield connection may result in malfunction and breakdown of the valve.

 The mounting surface of the valve has to be connected to the earth grounded machine frame. The earth ground wire from the valve connecting cable as well as the cable shield have to be tied to the protective earth terminal within the control unit. It is necessary to use a low ohmic potential connection between control unit and machine frame to prevent earth loops (cross section AWG 6).

Electrical Interfacing

Supply Voltage

The supply voltage for the valve has to cover the range of 22...30 V. Valve is de-energized below 19 V. The residual ripple may not exceed 5 % eff.

 The applied power supply must comply to the relevant regulations (DIN EN 61558) and must carry a CE-mark. The operating voltage for the valve must be free of inductive surges. Do not exceed the max. value of 30V! Higher voltage can lead to failure of the valve.

 The increased inrush current of the valve should be considered when selecting the power supply. A stabilized power supply with overcurrent limiting feature should not be used. Due to the inrush current of the valve the current limit circuit may respond prematurely and create problems during energizing of the supply voltage.

 The operation of the valve is blocked if the supply voltage polarity is interchanged.

 Each valve requires a separate pre-fuse of 4 Amp semi time-lag. Failure to observe this instruction may create irreparable damage of valve respectively incorporated system parts.

Wiring

Code 0, 6 + PE acc. EN 175201-804

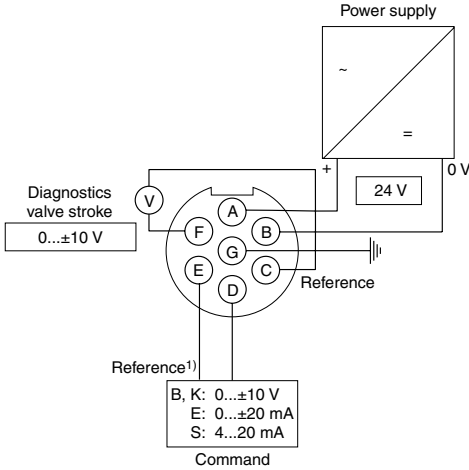

Code 5, 11 + PE acc. EN 175201-804

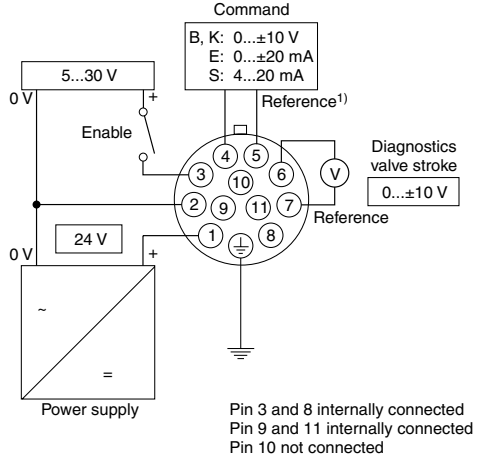

Code 7, 6 + PE acc. EN 175201-804 + enable

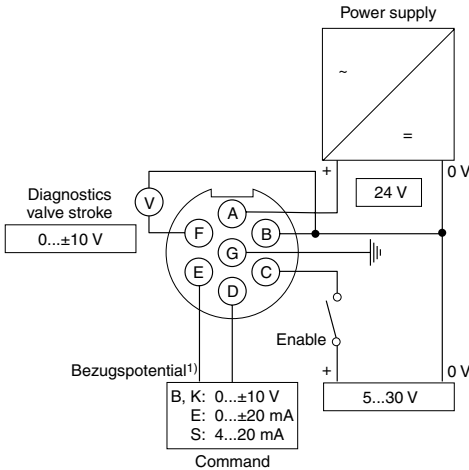

¹) Do not connect with supply voltage zero.

Operation Manual

Enable input (only for Code 5 / 11+PE as well as Code 7 / 6+PE)

A signal voltage enables the actuator drive of the valve. Continuous operation of the valve requires a permanent voltage 5...30 V (e.g. the supply voltage). In case of disabling the signal the valve will reach its power down position spring-actuated independently from the command signal value.

 The enable function represents no safety arrangement against unwanted valve operation in terms of accident prevention regulations.

Command signal input

The spool stroke is proportional to the command signal amplitude.

 The command input signal needs to be filtered as well as free of inductive surges and modulations. Due to the sensitivity of the valve a high signal quality is recommended. This will prevent malfunction.

 The option 4...20 mA uses the "3.6 mA" condition as breakdown-information. If the input signal line is interrupted, an evaluable failure information is available. In this case the actuator drive will be switched off. The drive will switch on when the input signal reaches a value of 3.8 mA, it switches off when the command falls below 3.6 mA. This determination follows the NAMUR-specification NE43.









NAMUR is an association of users of process control technology.

Diagnostic output









A diagnostic signal is available. Its voltage represents the operating condition of the valve.

 The output may drive a load of max. 5 mA. Exceeding of this limit leads to malfunction.

Valves NG06

| Code command signal | Command signal | Function | VCD actuator | Diagnostic signal |
|---------------------|----------------|---|--------------|------------------------|
| B | 0...+10 V |  | on | 0...+10 V |
| | 0...-10 V |  | on | 0...-10 V |
| | Overload | <input type="checkbox"/> | off | 12.5 V |
| E | 0...+20 mA |  | on | 0...+10 V |
| | 0...-20 mA |  | on | 0...-10 V |
| | Overload | <input type="checkbox"/> | off | 12.5 V |
| K | 0...+10 V |  | on | 0...-10 V |
| | 0...-10 V |  | on | 0...+10 V |
| | Overload | <input type="checkbox"/> | off | 12.5 V |
| S | 4...12 mA |  | on | 0...-10 V |
| | 12...20 mA |  | on | 0...+10 V |
| | 0...3.6 mA | <input type="checkbox"/> | off | Cable break, 12.5 V |
| | Overload | <input type="checkbox"/> | off | 12.5 V |

Valves NG10

| Code command signal | Command signal | Function | VCD actuator | Diagnostic signal |
|---------------------|----------------|---|--------------|------------------------|
| B | 0...+10 V |  | on | 0...-10 V |
| | 0...-10 V |  | on | 0...+10 V |
| | Overload | <input type="checkbox"/> | off | 12.5 V |
| E | 0...+20 mA |  | on | 0...-10 V |
| | 0...-20 mA |  | on | 0...+10 V |
| | Overload | <input type="checkbox"/> | off | 12.5 V |
| K | 0...+10 V |  | on | 0...+10 V |
| | 0...-10 V |  | on | 0...-10 V |
| | Overload | <input type="checkbox"/> | off | 12.5 V |
| S | 4...12 mA |  | on | 0...+10 V |
| | 12...20 mA |  | on | 0...-10 V |
| | 0...3.6 mA | <input type="checkbox"/> | off | Cable break, 12.5 V |
| | Overload | <input type="checkbox"/> | off | 12.5 V |

¹⁾ Diagnostic signal 12,5 V in error case. Spool moves in a defined position, please see ordering code „spool position at power down“.

Operation Manual

5. Operating Instructions

Spool Position at Power Down/Center Position



For valves with zero lap spools, distinction must be made between hydraulic neutral position and power-down position. Neutral position is taken at neutral input signal, corresponding to zero position of the hydraulic symbol. When the valve is switched off – no supply voltage, no enable, current signal (code S) < 3,8 mA – zero lap valves take the power down position (approximately 10 % opening) according to the ordering code. For valves with overlap spools, neutral position and power down position are the same (zero position).



Supply pressure must be ensured before valve is energized.

Solenoid Current Monitoring

If the actuator current time interval exceeds 10 seconds, the actuator is switched off to prevent overheating. For normal operating conditions this state will not be reached, but it may occur with a contaminated sluggish valve.



In this case the reason for the contamination should be rectified (hydraulic fluid exchange, filtration review, valve flushing).

The overcurrent shutoff condition may be reset by the actions below:

Code 0: Temporary disconnection of the supply voltage.

Code 5: Temporary disconnection of the enable signal.

Code 7: Temporary disconnection of the enable signal.



The shutoff of the VCD actuator due to overload will be indicated via the diagnostics output.

ProPxD parameterizing software

The ProPxD software permits comfortable parameter setting. Via the clearly arranged entry mask the parameters can be noticed and modified. Storage of complete parameter sets is possible as well as printout or record as a text file for further documentation.

The PC software can be downloaded free of charge at www.parker.com/isde – see page “Support” or directly at www.parker.com/propxd. Please check periodically for updates.

D_F_30 5715-687 UK.indd 16.09.21

Hardware requirements

- PC with operating system from Windows® XP upwards
- Interface RS232C
- display resolution at least 800 x 600
- connection cable between PC and electronic module
- memory requirement approximately 40 MB



If your PC has no serial interface according to RS232C standard you require in addition a USB-RS232C adapter.

Cable Specification



Attention! The valve electronic provides no USB interface, but can only be parametrized via an RS232C - connection. Therefore the usage of USB standard cables is not allowed and may result in damaging of valve respectively PC.

Parametrizing

Ordering code: 40982923



PC side connection

valve side connection

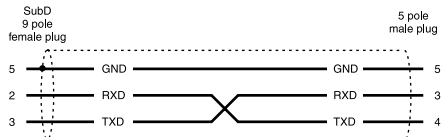

Parameterizing interface

Plug for parameterizing interface

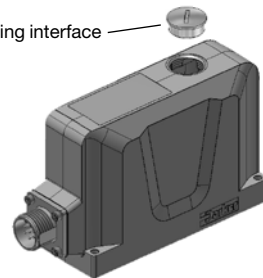

The cover plug has to be re-installed after completion of the parameterizing work.

Operation Manual

Program installation

Please check before installation if the above hardware requirements are met. If your PC has already stored an older version of the "ProPxD" program, it has to be deinstalled by using the Windows® - system control feature.

Program installation sequence:

- terminate the execution of other programs
 - execute the file "setup.exe"
 - follow the instructions on the screen
- Answer the question, if an older version should be overwritten, with "ok". During the installation you may change destination drive respectively installation path, if needed.

Please answer "ok" if at the end of the installation the program reports any system information. After successful installation the desktop display shows the ProPxD icon for starting the program.

Software Operating

Brief instruction for first startup:

- Connect the valve electronic to the supply voltage.
- Connect the valve electronic to a PC via the parametrizing cable.
- Start the operating program.
- After displaying the program respectively data base version a program window opens and the connected valve will be automatically identified (possibly a manual identification via the button "Receive all" is necessary).
- Select the desired version via the menu "Options/Optionen" with the menu item "Language/Sprache".
- The valve specific default parameters are already available within the parameter table.
- Parameter changes are possible via mouse or the arrow buttons on the bottom left within the program screen, also the parameter values may be edited via the keyboard.
- Modified parameters will be stored via the "Enter" key or via the button "Update list".
- Parameters have to be nonvolatile stored on the valve via the button "save parameter".
- The chosen parameters may be optionally stored on the PC via the "File"-menu with the menu item "Save as", data retrieving is always possible via the function "Load file"

Extended functions:

The user software is segmented into 2 parameter ranges:

- basic mode
- expert mode

For normal startup the basic mode is sufficient. It permits the setting of all application specific parameters to match the valve function with the task setting.

In case of special applications the valve parameters may be adapted via the expert mode. The operating mode may be selected from the "Options"- menu and remains after terminating and re-start of the program.



Changing of expert parameters is only permitted for qualified personnel. Incorrect settings may lead to malfunction! In case of parameter changes shut the drive down!

To prevent an unauthorized access for the expert mode, a password is requested. The name is "parker" and cannot be changed. Thus additionally to the button "Default" for loading of the default parameters, the button "Send parameter" appears in the "Expert"-operating mode. This button transmits only the setting of one single parameter to the connected valve. Thus a quick tuning of single parameters is permitted during the setup.



A horizontal bar graph readout between the communication buttons shows the data transfer state.



Because the ProPxD program has also without connection to the valve functionality, a manual pre-selection of the parameters is possible. After selection of the valve type via the menu "Options" the parameters may be set and stored for later transmission.

Note the design series while selection of the valve!

The "File" menu provides the functions "Printer setup", "Print preview" and "Print". The print preview includes the option for parameter set storage as text file (format.txt) prior to further processing. The "Options" menu provides also the selection of the RS232C interface port via the menu item "Port". Via the menu item "Load file" previously stored parameter sets may be loaded.

LED flashing signals of the valve electronics

- enable valve OK: approx. 0.5 Hz (slowly, green)
- disable valve OK: approx. 1 Hz (fast, green)
- valve error: approx. 10 Hz (very fast, green)

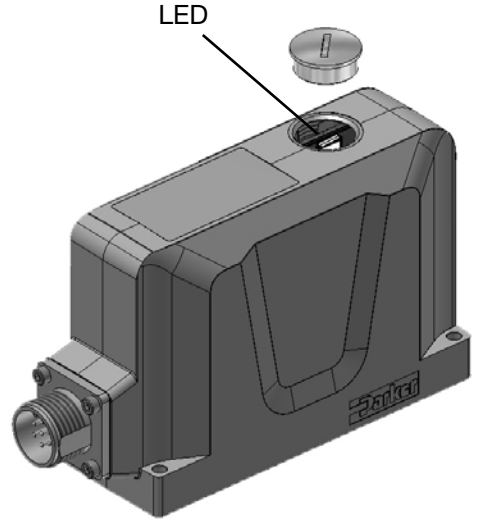

Closer information can be can be displayed via the ProPxD Parametrier software.

Error code

| Error code (additive) | Error description |
|-----------------------|-----------------------------|
| 0 | no errors |
| 1 | over current |
| 2 | cable break command signal |
| 4 | cable break feedback signal |
| 8 | undervoltage error |
| 16 | bus communication error |
| 32 | hardware failure |

Operation Manual

Adjustment parameters

The available parameters may be divided into multiple groups and are characterized by different letters:
S-parameters
P-parameters
J-parameters

Parameter overview for basic mode

| Parameter | Description | Unit | Parameter Range | | Default Setting | Comment |
|-----------|-------------------------------|--------|--|--------------------|-----------------|--|
| | | | from | up to | | |
| P1 | Zero adjust | % | -90.0 | 90 | 0.0 | |
| P3 | MAX channel A | % | 50.0 | 100.0 | 100.0 | |
| P4 | MAX channel B | % | 50.0 | 100.0 | 100.0 | |
| P7 | MIN channel A | % | 0.0 | 50.0 | 0.0 | |
| P8 | MIN channel B | % | 0.0 | 50.0 | 0.0 | |
| E17 | option command | - | 1 = ±10 V 2 = ±20 mA 3 = 4-20 mA 5 = ±10 mA | | 1 = ±10 V | only displayed, not adjustable |
| E19 | cable break detection command | - | 0 | 0 (±10 V / ±20 mA) | 0/1 | code S0 only, only displayed, not adjustable |
| | | | | 1 (4...20 mA) | | |
| E25 | MIN operating threshold | 0.01 % | 50 | 200 | 100 | |

Individual Description of Basic Parameters

| | |
|---|---|
| P1 | Adjustment of zero position shifting (offset). To compensate for unbalances. |
| P3 MAX + | Adjustment of maximum signal span for positive output signal. To match the command signal span to the valve operating range. |
| P4 MAX - | Adjustment of maximum signal span for negative output signal. To match the command signal span to the valve operating range. |
| P7 MIN + | Adjustment of stroke step for valve side A at min. operating threshold. To compensate for the overlap of the valve spool. |
| P8 MIN - | Adjustment of stroke step for valve side B at min. operating threshold. To compensate for the overlap of the valve spool. |
| E17 option command | Adjustment of the command signal option. To match the command signal input to the input signal mode. |
| E19 cable break detection command | Adjustment of the operating mode for the command cable break detection. To turn on resp. off of the cable break detection of the command signal at a selected command signal option of 4...20 mA. |
| E25 operating threshold | Adjustment of the MIN operating threshold. To match the response sensitivity for the MIN-stroke step. |

Overview for additional expert mode parameter

| Parameter | Description | Unit | Parameter Range | | Default Setting | Comment |
|-----------|---|------|--|-------|-----------------|---------|
| | | | from | up to | | |
| J8 | Min supply voltage supervision | V | 17 | 28 | 18 | |
| J9 | Relay time out off range min supply voltage | ms | 0 | 3200 | 1000 | |
| J12 | Errorhandling | | 0 = no fault acknowledgement necessary; 255 = fault acknowledgement necessary; 768 = no fault acknowledgement + fault report about diagnosis; 1023 = fault acknowledgement + fault report about diagnosis | | 768 | |

Individual description of additional expert parameters

| | |
|--|--|
| J8 Min supply voltage supervision | Adjustment of the minimal supply voltage: Below this supply voltage the valve switches off with an error message. |
| J9 Relay time out off range min supply voltage | Adjustment of the runtime monitoring: The supply voltage must be at least constantly before the valve is ready for operation. |
| J12 Errorhandling | Adjustment of the fault response or report: 0 = no fault acknowledgement necessary 255 = fault acknowledgement necessary 768 = no fault acknowledgement + Fault report about diagnosis 1023 = fault acknowledgement + Fault report about diagnosis |

Operation Manual

Error messages

Malfunctions when using the ProPxD software program will be indicated via appropriate failure messages.

Failure messages and corrective actions:

| Failure message | Description/corrective action |
|---|---|
| The Com Port is not available! | Terminate the other program, or quit the message and select another RS232C port via the menu "Options > Port". Afterwards reconnect the parametrizing cable. |
| Unable to open COM port | Com port is not available. Quit the message and select another RS232C port via the menu "Options > Port". Afterwards reconnect the parametrizing cable. |
| There is no module/valve connected or the communication is disturbed! Please check also the interface! | No data exchange possible. Either the electronic has been removed, the port is mismatched, or the connection will be disturbed by strong electrical fields. Check if the Com port is set for "9600, 8, 1. none, none" via the menu "Options > Port". |
| Wrong password | Retype the password, notice the exact spelling (case sensitivity). |
| Wrong input | An invalid character or a value outside the permitted range has been used at parameter entry. |
| Keep the entered parameters? | During parameter loading from the electronics memory the preset parameters from the left hand screen display may be rejected or maintained. |
| The chosen module/valve isn't the same as the connected hardware. Attention! Unsaved parameters will be lost. | In principle, parameters dedicated to a type which deviates from the connected valve may be edited. However, for data transmitting the correct valve has to be connected. If parameters will be loaded from a valve which deviates from the selected one, the parameters from the left hand side screen display of the program will be overwritten. |
| The chosen hardware isn't the same as the connected module/valve. | The wrong valve type has been selected from the database, afterwards the function "send all" has been executed. |
| Attention! Factory settings will be changed! Transmit anyhow? | Default parameters has been read out from the database instead from the valve via the function "receive all". |
| file name.pxd already exists. Do you want to replace the file? | The file name already exists within the indicated directory. Select another name, another directory or overwrite the existing file with "OK". |

Air Bleeding of Hydraulic System

During initial startup, after an oil change as well as after the opening of lines or valves the hydraulic system must be air bled.

Filter

The function and lifetime of the valve are strongly affected by the cleanliness of the fluid.

Purity level class of 18/16/13 acc. ISO4406 is required.

Flushing

It is recommended to flush the pipelines by short circuiting the pressure and return lines. This prevents the installation dirt from entering the valve.

6. Trouble Shooting

Basis of troubleshooting is always a systematic approach.



Troubleshooting in a hydraulic system requires detailed knowledge about function and construction of the system. Therefore the work may exclusively be performed by qualified personnel.

For suspect of a sluggish spool the valve may be flushed with clean pressure fluid.

| malfunction at hydraulic load runtime | | | | | | | | |
|--|---|---|---|----------------------------------|--------------------|---|--|---|
| - generally no function | | | | | | | | |
| - high frequent oscillation | | | | | | | | |
| - low frequent oscillation | | | | | | | | |
| - one way operation only | | | | | | | | |
| - speed variations at unchanging command | | | | | | | | |
| - different speeds depending on travel direction | | | | | | | | |
| - speed too low | | | | | | | | |
| - drifting without command | | | | | | | | |
| - poor dynamic | | | | | | | | |
| | | | | possible reasons for malfunction | corrective actions | | | |
| X | | | | | | | hydraulic pump resp. motor defective | replace hydraulic pump resp. motor |
| X | X | X | X | X | X | X | drive overloaded | reduce pressure resp. speed, increase valve size |
| X | X | X | X | X | X | X | valve contaminated | clean pressure fluid, filter / flush valve |
| X | X | X | | X | X | X | hydraulic fluid too viscous / too cold | change fluid grade, provide operational temperature |
| X | X | X | | | | | too low oil level within tank | refill pressure fluid |
| X | | | X | X | X | | filter contaminated | replace filter |
| X | X | | | X | X | | supply voltage too low | keep supply voltage range |
| | X | | | | | | supply voltage carries too much ripple | reduce ripple |
| X | | X | | | X | | command signal too low | increase command signal |
| | X | | | | | | command signal carries too much ripple | reduce ripple |
| | | X | | X | | | center position adjustment incorrect | check center position adjustment |
| X | X | | X | X | X | | contacts of central connector contaminated | clean contacts / replace plug |
| X | | | | | | | feed cable interrupted | fix feed cable |
| X | X | X | X | X | X | X | wiring sequence incorrect | correct wiring sequence |
| | X | | | | | X | feed cable without shielding | change cable grade |
| X | | | | | | | pilot pressure too low or failed | increase pilot pressure to min. 20 bar |
| | X | | | | X | X | pilot pressure too low | increase pilot pressure to min. 20 bar |
| | | | | | X | X | pilot pressure too low | increase pilot pressure to min. 50 bar |

7. Accessories / Spare Parts

Accessories

The following accessories are available for the valve series DFplus:

Bolt kit

D1FE/D1FP ordering code BK 375
D3FE/D3FP/D30FP ordering code BK 385

Female connection

Code 0: 6+PE ordering code 5004072
Code 5: 11-PE ordering code 5004711
Code 7: 6-PE ordering code 5004072

Spare Parts

Seal kit NBR

D1FE/D1FP ordering code SK-D1FP
D3FE/D3FP/D30FP ordering code SK-D3FP

